

## Cordless Electric Airless Sprayers

# 3A8179C

EN

*For portable airless spraying of architectural paints and coatings (390 PC). For the application of line striping materials (ES 500 Stencil). Not approved for use in explosive atmospheres or hazardous (classified) locations. For professional use only.*

**390 PC Cordless Models: 25T804, 826280, 25T863, 25T943, 25T882, 25T805**

**ES 500 Stencil Models: 25U513, 25U514**

*3300 psi (228 bar, 22.8 MPa) Maximum Working Pressure*



### Important Safety Instructions

Read all warnings and instructions in this manual and related manuals before using the equipment. Be familiar with the controls and the proper usage of the equipment. Save these instructions.

### Related Manuals

Manual	Description
311861	Gun (Contractor/FTX)
334599	Pump
3A6285	Gun (Contractor PC)
311254	Silver/Flex Plus

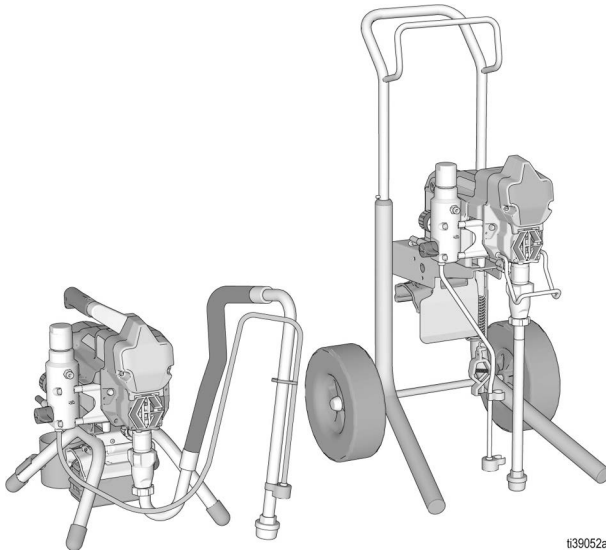







ti39052a

*Use only genuine Graco replacement parts.  
The use of non-Graco replacement parts may void warranty.*

## Contents

<b>Models</b> .....	<b>3</b>
<b>Important Grounding Information</b> .....	<b>4</b>
<b>Warnings</b> .....	<b>5</b>
<b>Component Identification</b> .....	<b>8</b>
Stand Models .....	8
Hi-Boy .....	9
<b>Grounding Instructions</b> .....	<b>10</b>
Pails .....	11
<b>Pressure Relief Procedure</b> .....	<b>12</b>
Trigger Lock .....	13
<b>Setup</b> .....	<b>14</b>
Battery Installation and Removal .....	17
<b>Startup</b> .....	<b>18</b>
<b>Operation</b> .....	<b>20</b>
Spray Tip Installation .....	20
Spray .....	20
Clear Tip Clog .....	22
Cleanup .....	23
Cleaning Fluid Compatibility .....	26
<b>Maintenance</b> .....	<b>27</b>
<b>Troubleshooting</b> .....	<b>28</b>
Mechanical/Fluid Flow .....	28
Electrical .....	31
<b>Parts</b> .....	<b>32</b>
<b>Gun, Hose and Labels</b> .....	<b>38</b>
<b>Wiring Diagram</b> .....	<b>39</b>
<b>Technical Specifications</b> .....	<b>40</b>
<b>California Proposition 65</b> .....	<b>41</b>
<b>Graco Standard Warranty</b> .....	<b>42</b>
<b>Graco Information</b> .....	<b>43</b>

## Models

	Battery Voltage VDC	Charger Voltage VAC	Model	Stand 	Hi-Boy 
	60 USA/CA	120 USA/CA	390 PC Cordless	25T804	25T805
			ES 500 Stencil	25U513	
			NOVA 390 PC Cordless	826280	
	54 EMEA/UK	230 EMEA	ES 500 Stencil	25U514	
			390 PC Classic Cordless	25T863	
	54 EMEA/UK	230 EMEA	390 PC Classic Cordless	25T943	
	54 ANZ/AP	230 ANZ/AP	390 PC Cordless	25T882	

**NOTE:** See **Gun, Hose and Labels**, page 38 for spray gun information.

The 390 PC Cordless Sprayer is compatible with the following DEWALT® FLEXVOLT® 54V and 60V batteries:

- DCB606 - 60V/2ah (20V/6ah)
- DCB546 - 54V/2ah (18V/6ah)
- DCB609 - 60V/3ah (20V/9ah)
- DCB547 - 54V/3ah (18V/9ah)
- DCB548 - 54V/3ah (18V/12ah)
- DCB612 - 60V/4ah (20V/12ah)

### Related DEWALT Manuals

Manual	Description	Region
N463494	DEWALT DCB118 Fast Charger Manual	USA/CA
N463510 N463511	DEWALT DCB118-QW Fast Charger Manual (Part 1 and 2)	EMEA
N501136	DEWALT DCB118-XE Fast Charger Manual	ANZ/AP

# Important Grounding Information



## Important Grounding Information

Before using your sprayer read this Owners Manual for complete instructions on proper use and safety warnings.

The following information is intended to help you understand when to use the grounding wire and clamp provided with your sprayer.







Please read the information on the material container label to determine if it is oil-based or flammable. Ask for a Safety Data Sheet (SDS) from your supplier. The container label and SDS will explain the contents of the material and the specific precautions related to it.

Paints, coatings and clean-up materials generally fit into one of the following **3 basic types**:

<b>Grounding Wire and Clamp Required?</b>	<b>Type of Material</b>
<b>No</b>	<b>WATER-BASED:</b> The container label should indicate that the material can be cleaned up with soap and water.
<b>Yes</b> 	<b>OIL-BASED:</b> The container label should indicate that the material is <b>COMBUSTIBLE</b> and can be cleaned up with mineral spirits or non-flammable paint thinner. Use oil-based material outdoors or in a well-ventilated indoor area with a flow of fresh air. See the safety warnings in this manual. Follow <b>Grounding Instructions</b> , page 10, when using this type of material.
<b>Yes</b> 	<b>FLAMMABLE:</b> This type of material contains flammable solvents such as xylene, toluene, naphtha, MEK, lacquer thinner, acetone, denatured alcohol, and turpentine. The container label should indicate that this material is <b>FLAMMABLE</b> . Use flammable materials outdoors or in a well-ventilated area with a flow of fresh air. Follow <b>Grounding Instructions</b> , page 10, when using this type of material.

## Warnings

The following warnings are for the setup, use, grounding, maintenance, and repair of this equipment. The exclamation point symbol alerts you to a general warning and the hazard symbols refer to procedure-specific risks. When these symbols appear in the body of this manual or on warning labels, refer back to these Warnings. Product-specific hazard symbols and warnings not covered in this section may appear throughout the body of this manual where applicable.

 <b>WARNING</b>	
 	<p><b>FIRE AND EXPLOSION HAZARD (GROUNDING)</b></p> <p>Oil-based and flammable materials can generate static electricity when sprayed or flushed. Static electricity creates a risk of fire or explosion in the presence of paint or solvent fumes. To help prevent fire and explosion when using oil-based or flammable materials:</p> <ul style="list-style-type: none"> <li>• Connect the grounding wire and clamp to a true earth ground.</li> <li>• If there is static sparking or if you feel a shock, stop operation immediately. Do not use sprayer until you identify and correct the problem.</li> <li>• All parts of the spray system, including the pump, hose assembly, spray gun, and objects in and around the spray area shall be properly grounded to protect against static discharge and sparks. Use Graco conductive or grounded high-pressure airless paint sprayer hoses. Follow <b>Grounding Instructions</b>, page 10.</li> <li>• Verify that all containers and collection systems are grounded to prevent static discharge. Do not use pail liners unless they are anti-static or conductive.</li> </ul>
   	<p><b>FIRE AND EXPLOSION HAZARD</b></p> <p>Flammable fumes, such as solvent and paint fumes, in work area can ignite or explode. To help prevent fire and explosion:</p> <ul style="list-style-type: none"> <li>• Do not spray flammable or combustible materials near an open flame or sources of ignition such as cigarettes, motors, and electrical equipment.</li> <li>• Do not use a paint or a solvent containing halogenated hydrocarbons.</li> <li>• Do not spray flammable or combustible liquids in a confined area.</li> <li>• Keep spray area well-ventilated. Keep a good supply of fresh air moving through the area.</li> <li>• Keep pump assembly in a well-ventilated area at least 20 feet (6.1 m) from the spray area when spraying, flushing, cleaning, or servicing. Do not spray pump assembly.</li> <li>• Do not smoke in the spray area or spray where sparks or flame is present.</li> <li>• Do not operate light switches, engines, or similar spark producing products in the spray area.</li> <li>• Keep area clean and free of paint or solvent containers, rags, and other flammable materials.</li> <li>• Know the contents of the paints and solvents being sprayed. Read all Safety Data Sheets (SDSs) and container labels provided with the paints and solvents. Follow the paint and solvent manufacturer's safety instructions.</li> <li>• Keep a working fire extinguisher in the work area.</li> </ul>

## **WARNING**



### **SKIN INJECTION HAZARD**

High-pressure spray is able to inject toxins into the body and cause serious injury that can result in amputation. In the event that injection occurs, **get immediate surgical treatment.**



- Do not aim the gun at, or spray any person or animal.
- Keep hands and other body parts away from the discharge. For example, do not try to stop leaks with any part of the body.
- Always use the spray tip guard. Do not spray without spray tip guard in place.
- Use Graco spray tips.
- Use caution when cleaning and changing spray tips. In the case where the spray tip clogs while spraying, follow the **Pressure Relief Procedure** for turning off the unit and relieving the pressure before removing the spray tip to clean.
- Equipment maintains pressure after power is shut off. Do not leave the equipment energized or under pressure while unattended. Follow the **Pressure Relief Procedure** when the equipment is unattended or not in use, and before servicing, cleaning, or removing parts.
- Check hoses and parts for signs of damage. Replace any damaged hoses or parts.
- This system is capable of producing 3300 psi (228 bar, 22.8 MPa). Use Graco parts or accessories that are rated a minimum of 3300 psi (228 bar, 22.8 MPa).
- Always engage the trigger lock when not spraying. Verify the trigger lock is functioning properly.
- Verify that all connections are secure before operating the unit.
- Know how to stop the unit and bleed pressure quickly. Be thoroughly familiar with the controls.









### **EQUIPMENT MISUSE HAZARD**

Misuse can cause death or serious injury.



- Always wear appropriate gloves, eye protection, and a respirator or mask when spraying.
- Do not operate or spray near children. Keep children away from equipment at all times.
- Do not overreach or stand on an unstable support. Keep effective footing and balance at all times.
- Stay alert and watch what you are doing.
- Do not operate the unit when fatigued or under the influence of drugs or alcohol.
- Do not kink or over-bend the hose.
- Do not expose the hose to temperatures or to pressures in excess of those specified by Graco.
- Do not use the hose as a strength member to pull or lift the equipment.
- Do not spray with a hose shorter than 25 feet.
- Always replace cracked, broken or missing parts immediately with genuine Graco parts. See **Parts**, page 32.
- Do not alter or modify equipment. Alterations or modifications may void agency approvals and create safety hazards.
- Use only in dry locations. Do not expose to water or rain.
- Use in well-lit areas.
- Make sure all equipment is rated and approved for the environment in which you are using it.
- Do not operate or clean sprayer with the battery shield open.

## **WARNING**

	<p><b>PRESSURIZED ALUMINUM PARTS HAZARD</b></p> <p>Use of fluids that are incompatible with aluminum in pressurized equipment can cause serious chemical reaction and equipment rupture. Failure to follow this warning can result in death, serious injury, or property damage.</p> <ul style="list-style-type: none"> <li>• Do not use 1,1,1-trichloroethane, methylene chloride, other halogenated hydrocarbon solvents or fluids containing such solvents.</li> <li>• Do not use chlorine bleach.</li> <li>• Many other fluids may contain chemicals that can react with aluminum. Contact your material supplier for compatibility.</li> </ul>
 	<p><b>BATTERY AND CHARGER COMPATIBILITY HAZARD</b></p> <ul style="list-style-type: none"> <li>• Only use DEWALT brand 54V Max or 60V Max batteries and battery chargers with this tool.</li> <li>• READ ALL INSTRUCTIONS included with this tool regarding the safety and usage of DEWALT batteries and battery chargers.</li> <li>• Do not wash or spray down battery.</li> <li>• Do not clean the battery with anything other than a cloth moistened with water.</li> </ul>
	<p><b>TOXIC FLUID OR FUMES HAZARD</b></p> <p>Toxic fluids or fumes can cause serious injury or death if splashed in the eyes or on skin, inhaled, or swallowed.</p> <ul style="list-style-type: none"> <li>• Read Safety Data Sheets (SDSs) to know the specific hazards of the fluids you are using.</li> <li>• Store hazardous fluid in approved containers, and dispose of it according to applicable guidelines.</li> </ul>
 	<p><b>MOVING PARTS HAZARD</b></p> <p>Moving parts can pinch, cut, or amputate fingers and other body parts.</p> <ul style="list-style-type: none"> <li>• Keep clear of moving parts.</li> <li>• Do not operate equipment with protective guards or covers removed.</li> <li>• Equipment can start without warning. Before checking, moving, or servicing equipment, follow the <b>Pressure Relief Procedure</b> and disconnect all power sources.</li> </ul>
	<p><b>PERSONAL PROTECTIVE EQUIPMENT</b></p> <p>Wear appropriate protective equipment when in the work area to help prevent serious injury, including eye injury, hearing loss, inhalation of toxic fumes, and burns. Protective equipment includes but is not limited to:</p> <ul style="list-style-type: none"> <li>• Protective eyewear, and hearing protection.</li> <li>• Respirators, protective clothing, and gloves as recommended by the fluid and solvent manufacturer.</li> </ul>

# Component Identification

## Component Identification

### Stand Models

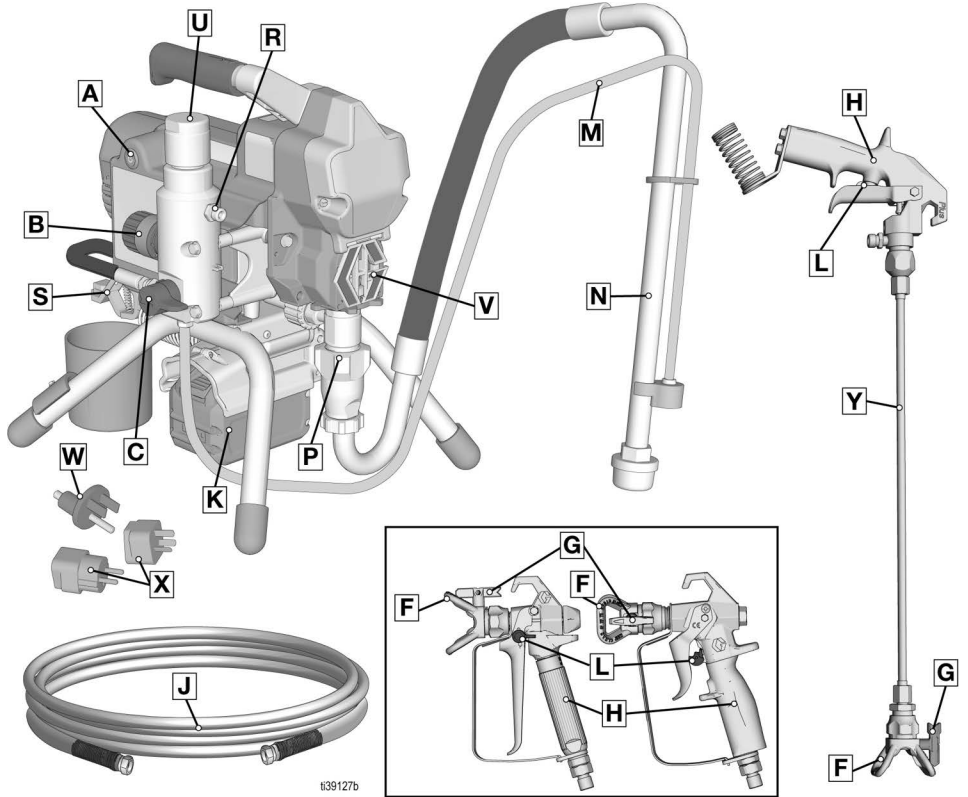

t39127b

A	ON/OFF Switch
B	Pressure Control
C	Prime/Spray Valve
F	Tip Guard
G	Spray Tip
H	Gun
J	Airless Hose
K	Battery
L	Trigger Lock
M	Drain Tube

N	Siphon Hose
P	Pump
R	Fluid Outlet
S	Grounding Wire and Clamp
U	Filter
V	Finger Guard / TSL Fill Point
W	Ground Outlet Adapter
X	Ground Plug Adapter
Y	Extension Tube for Stencil Gun
	Model/Serial Tag (Not shown, located on bottom of unit.)



# Component Identification

## Hi-Boy

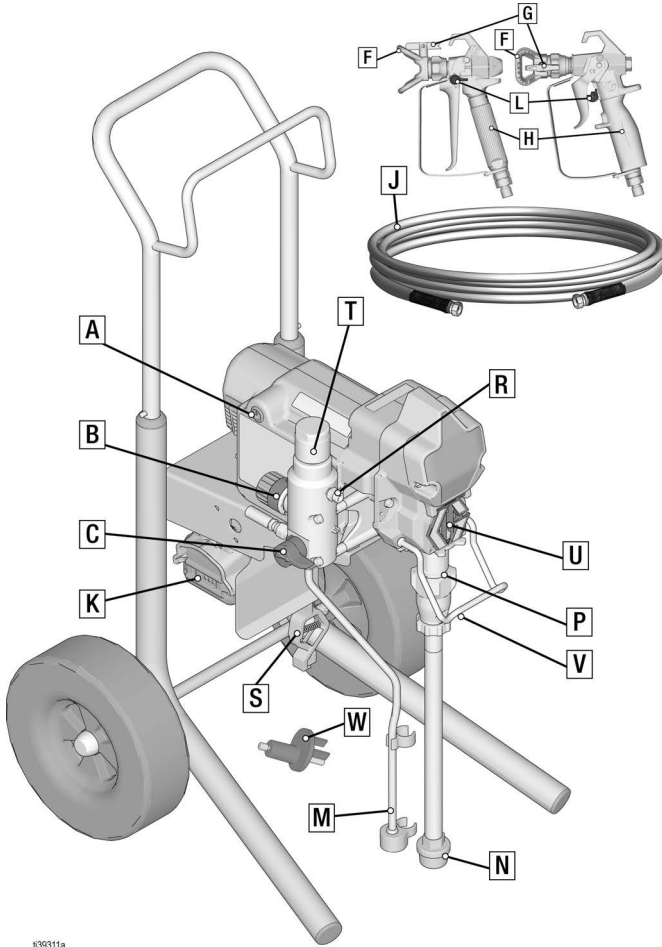

t39311a

A	ON/OFF Switch
B	Pressure Control
C	Prime/Spray Valve
F	Tip Guard
G	Spray Tip
H	Gun
J	Airless Hose
K	Battery
L	Trigger Lock
M	Drain Tube

N	Siphon Hose
P	Pump
R	Fluid Outlet
S	Grounding Wire and Clamp
T	Filter
U	Finger Guard / TSL Fill Point
V	Pail Hook
W	Ground Outlet Adapter
	Model/Serial Tag (Not shown, located on bottom of unit.)

# Grounding Instructions

## Grounding Instructions (Oil-Based and Flammable Materials)



The equipment must be grounded to reduce the risk of static sparking. A static spark can cause fumes to ignite or explode causing serious injury. A good ground provides an escape wire for the electric current.

The sprayer is equipped with a grounding wire and clamp. The clamp must be connected to a true earth ground when spraying or flushing oil-based or flammable materials.

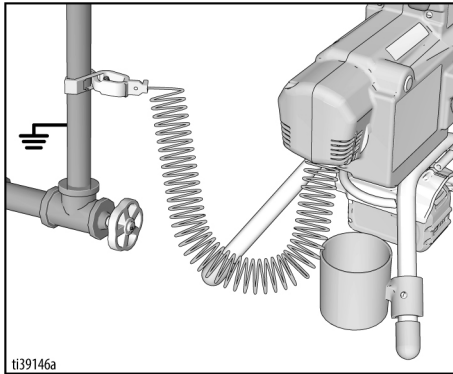

A water pipe can be used as a true earth ground. Connect the grounding wire and clamp to a metal water pipe.

A properly grounded electrical outlet can also be used as a true earth ground. Use the provided outlet adapter.

Plug the adapter in to a grounded outlet. Connect the grounding wire and clamp to the metal stud on the adapter. If the ground wire is not long enough to reach a grounded electrical outlet, use a 3-wire grounded extension cord between the adapter and outlet.

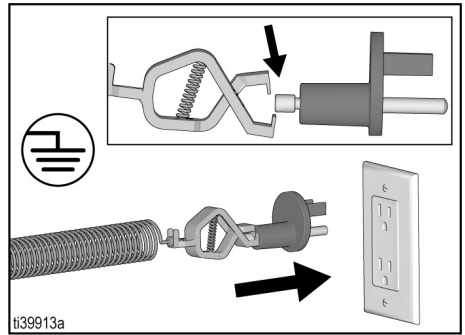

**Fluid hoses:** Use only electrically conductive hoses with a maximum of 300 ft. (91 m) combined hose length to ensure grounding continuity.

**Spray gun:** Grounded through connection to a properly grounded fluid hose and pump.

## Pails

**Solvents and oil-based materials:** follow local codes and regulations. Use only conductive metal pails, placed on a grounded surface such as concrete.

Do not place pail on a non-conductive surface such as paper or cardboard which interrupts grounding continuity.



**Always ground a metal pail:** connect a ground wire to the pail. Clamp one end to the pail and the other end to a true earth ground such as a water pipe.

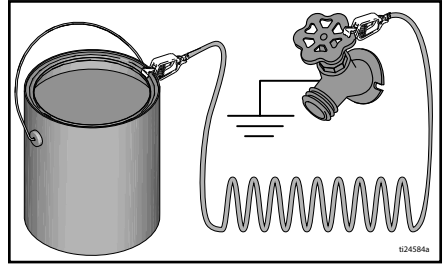

**To maintain ground continuity when sprayer is flushed or pressure is relieved:** hold metal part of spray gun firmly to the side of a grounded metal pail then trigger the gun.

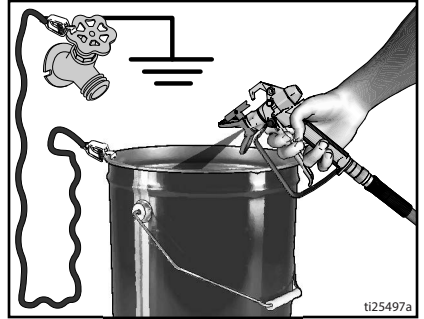

# Pressure Relief Procedure

## Pressure Relief Procedure



Follow the Pressure Relief Procedure whenever you see this symbol.

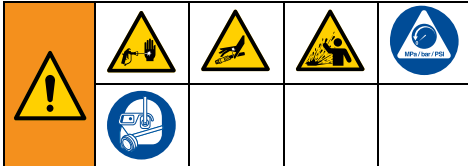

This equipment stays pressurized until pressure is manually relieved. To help prevent serious injury from pressurized fluid, such as skin injection, splashed fluid and moving parts, follow the Pressure Relief Procedure whenever sprayer is stopped and before sprayer is cleaned or checked, and before equipment is serviced.

1. Engage the trigger lock.

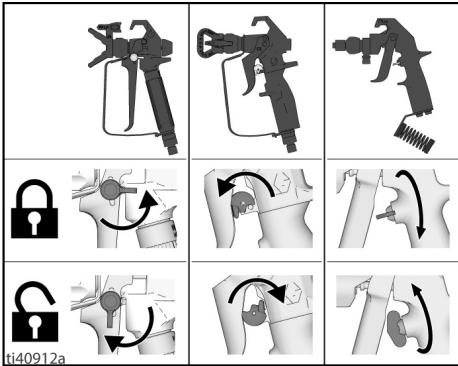

2. Turn the ON/OFF switch to the **OFF** position. Power button is illuminated when **ON**. Wait 7 seconds for power to dissipate.

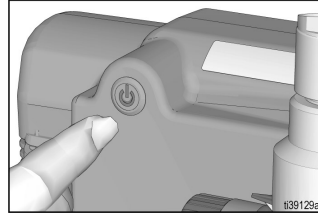

3. Turn pressure control to lowest setting. Disengage the trigger lock.

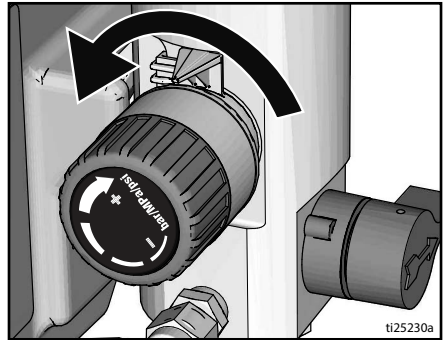

4. Hold a metal part of the gun firmly to a grounded metal pail. Trigger the gun to relieve pressure.

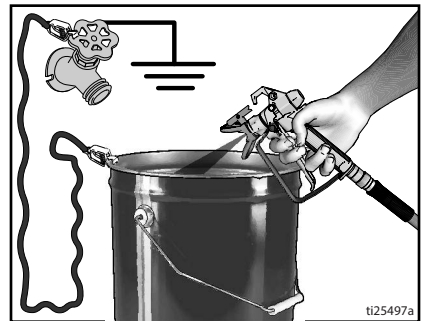

5. Engage the trigger lock.

# Pressure Relief Procedure

6. Put drain tube in a pail. Turn prime/spray valve down. Leave prime/spray valve in down (drain) position until you are ready to spray again.

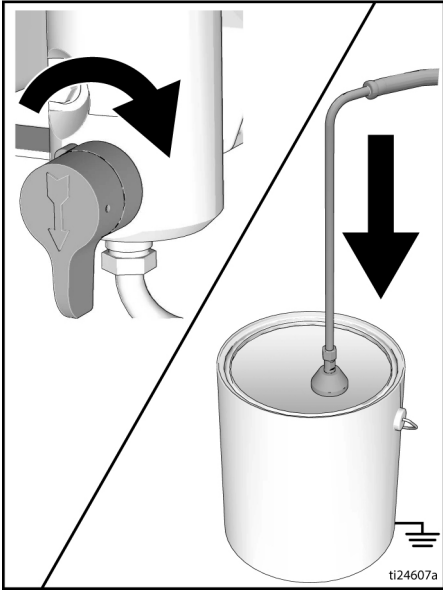

7. If you suspect the spray tip or hose is clogged or that pressure has not been fully relieved:
  - a. **VERY SLOWLY** loosen the tip guard retaining nut or the hose end coupling to relieve pressure gradually.
  - b. Loosen the nut or coupling completely.
  - c. Clear hose or tip obstruction.

## Trigger Lock

Always engage the trigger lock when sprayer is stopped to prevent the gun from being triggered accidentally by hand or if dropped or bumped.

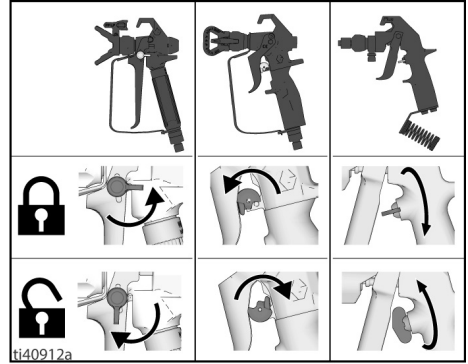

# Setup

## Setup

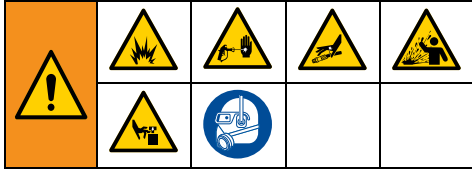

When unpacking sprayer for the first time or after long term storage perform setup procedure. When first setup is performed remove shipping plug from fluid outlet.

1. Connect Graco airless hose to fluid outlet. Use two wrenches to tighten securely.

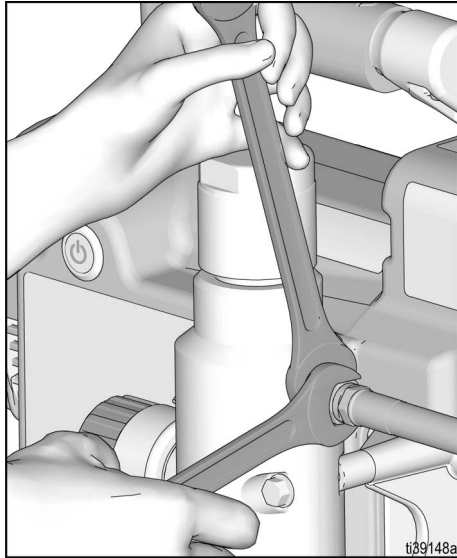

2. Connect other end of hose to gun.

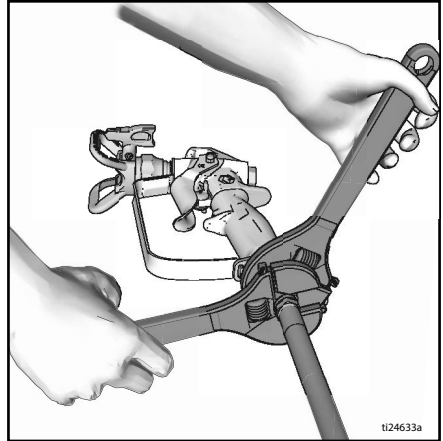

3. Use wrenches to tighten securely.
4. Engage trigger lock.

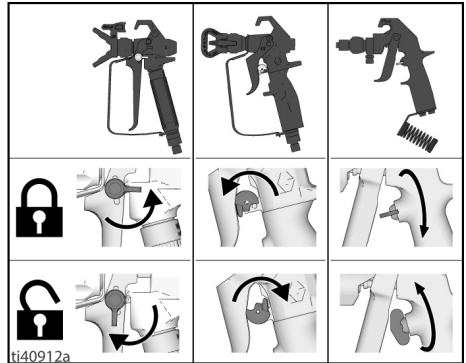

5. Remove tip guard.

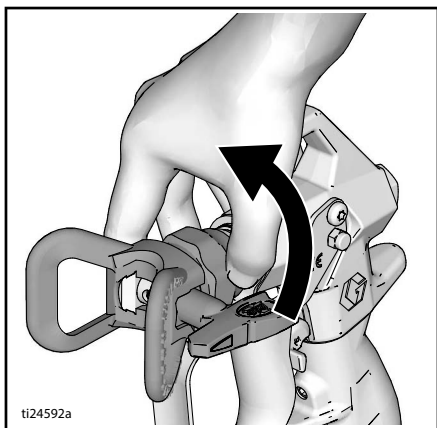

6. When unpacking sprayer for the first time remove packaging materials from inlet strainer. After long term storage check inlet strainer for clogs and debris.

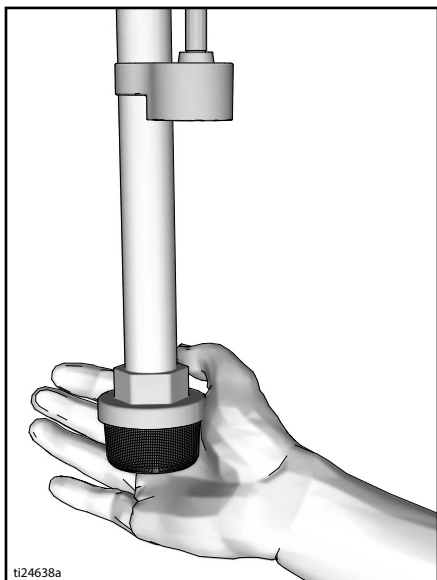

7. Fill throat packing nut with TSL to prevent premature packing wear. Do this daily or each time you spray.
- Place the TSL bottle nozzle into the top center opening in the grill at the front of the sprayer.
  - Squeeze bottle to dispense enough TSL to fill the space between the pump rod and packing nut seal.

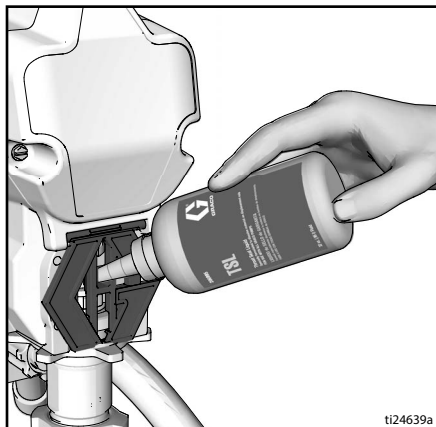

8. Make certain ON/OFF switch is **OFF**. Power button is illuminated when it is **ON**.

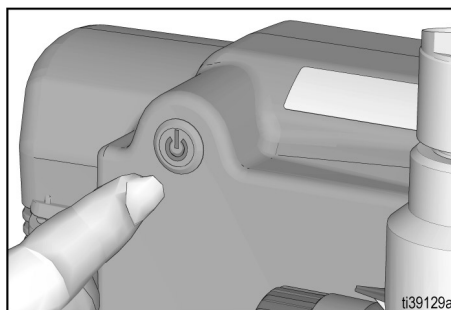

# Setup

9. Turn prime/spray valve down.

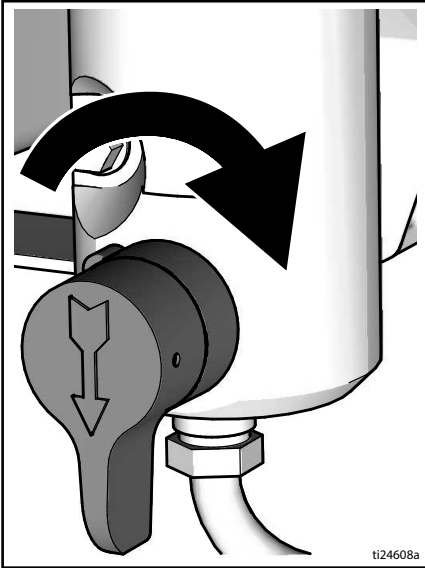

10. Place fluid intake with drain tube in grounded metal pail partially filled with flushing fluid. When spraying oil-based or flammable, follow **Grounding Instructions**, page 10.

**NOTE:** New sprayers are shipped with storage fluid that must be flushed out with mineral spirits prior to using the sprayer.

Check flushing fluid for compatibility with material that is to be sprayed, see **Cleaning Fluid Compatibility**, page 26. A secondary flush with a compatible fluid may be necessary.

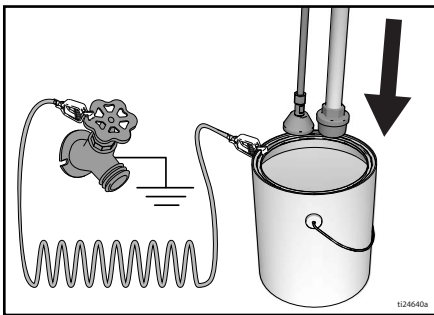

11. Turn pressure control to lowest setting.
12. Install battery, see **Battery Installation and Removal**, page 17.
13. Turn ON/OFF switch to **ON** position.
14. Increase pressure 1/2 turn to start motor. Allow fluid to flush through sprayer for one minute.
15. Turn prime/spray valve horizontal. Disengage trigger lock.

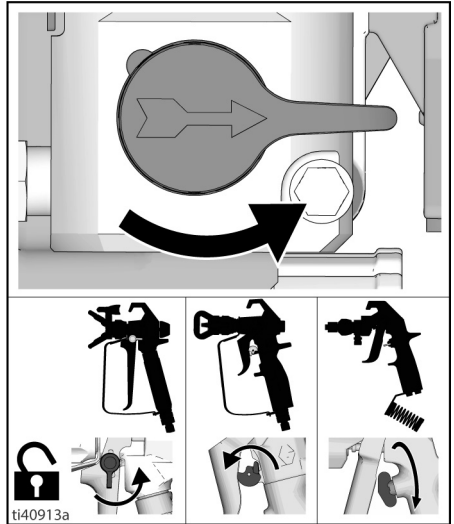

16. Hold a metal part of the gun firmly to a grounded metal pail. Trigger gun and flush until clean.
17. Turn ON/OFF switch to **OFF** position.
18. Remove gun and engage trigger lock.
19. If the initial flushing fluid is not compatible with the material that is to be sprayed, a second flush is needed. Repeat steps 11-18.
20. Re-install tip guard, see **Spray Tip Installation**, page 20.
21. Sprayer is now ready to start up and spray.



## Battery Installation and Removal

**Always start with a fully charged Battery. Do not splash or immerse Battery or charger in water. See Battery and charger information shipped with the sprayer.**

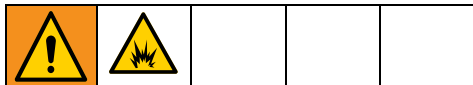

Replace and charge Battery only in a well-ventilated area and away from flammable or combustible materials, including paints and solvents.

Remove and install Battery into the sprayer as follows:

1. Remove the used Battery, if in place.

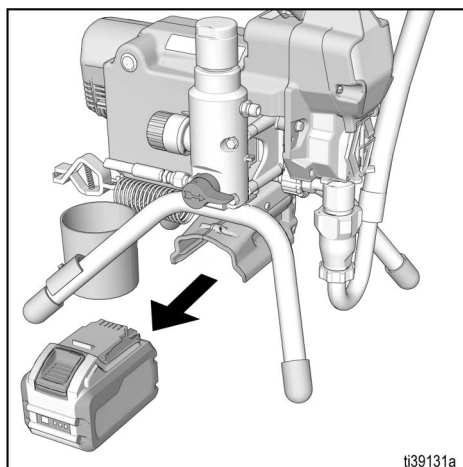

2. Install battery by aligning the battery pack with the rails inside the sprayer and sliding it in until the battery pack is firmly seated. Ensure that it does not disengage.

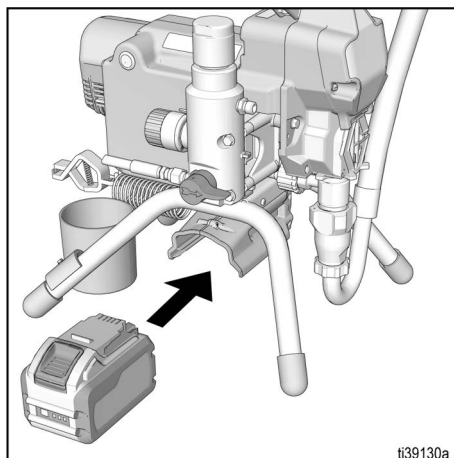

## Startup

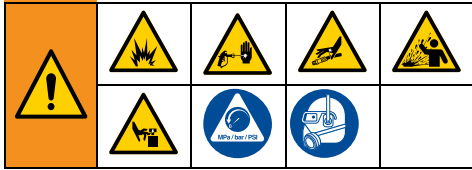

1. Perform **Pressure Relief Procedure**, page 12.
2. Turn pressure control to lowest pressure.

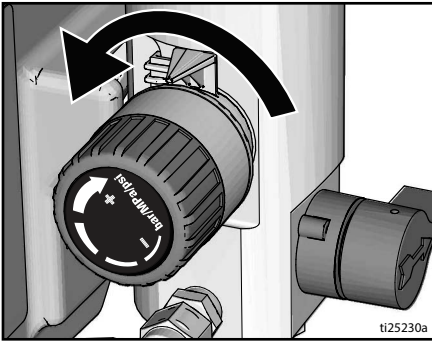

3. Install battery, see **Battery Installation and Removal**, page 17.
4. When spraying oil-based or flammable material, follow **Grounding Instructions**, page 10.
5. Turn ON/OFF switch to **ON** position. Power button is illuminated when it is **ON**.

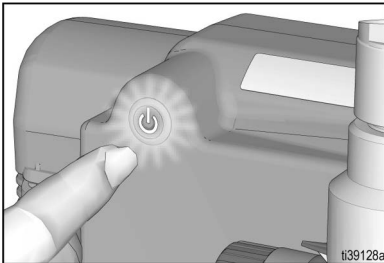

6. Place fluid intake in paint pail. Place drain tube in waste pail.

7. Increase pressure 1/2 turn to start motor. Allow paint or other material to circulate through sprayer until material flows out the drain tube.

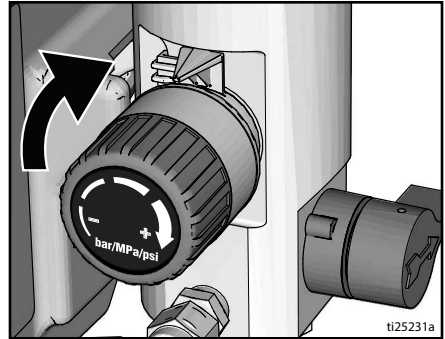

8. Turn prime/spray valve horizontal. Disengage trigger lock.

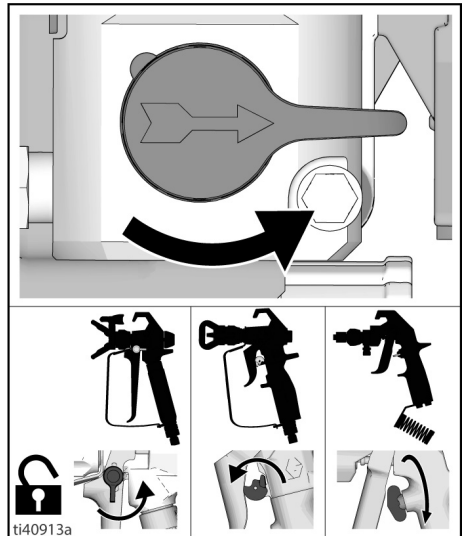

9. Hold gun against grounded metal waste pail. Trigger gun at least 1 minute until paint appears.

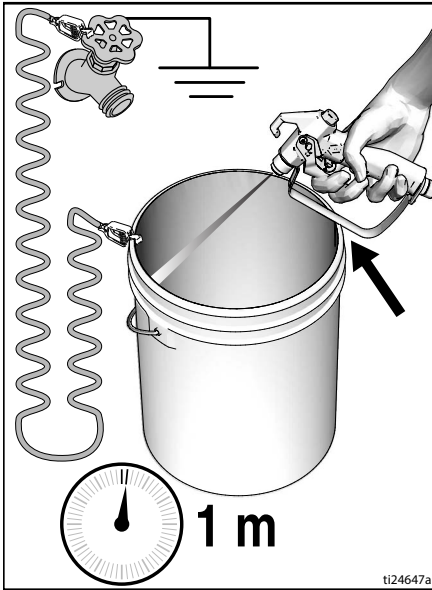

10. Move gun to paint pail and trigger for 20 seconds. Release trigger and allow sprayer to build pressure. Engage trigger lock.

<p>High-pressure spray is able to inject toxins into the body and cause serious bodily injury. Do not stop leaks with hand or rag.</p>				

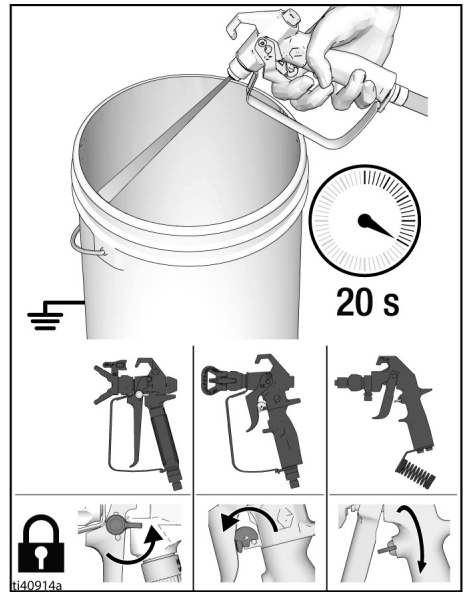

11. Inspect Airless Hose and hose connections for leaks. If leaks occur, perform **Pressure Relief Procedure**, page 12, then tighten all fittings and repeat **Startup** procedure. If there are no leaks, continue with **Operation**, page 20.

# Operation

## Operation

### Spray Tip Installation



To avoid serious injury from skin injection, do not put your hand in front of the Spray Tip when installing or removing the Spray Tip and Spray Tip Guard.

1. Perform **Pressure Relief Procedure**, page 12.
2. Use spray tip (A) to insert OneSeal™ (B) into tip guard (C).

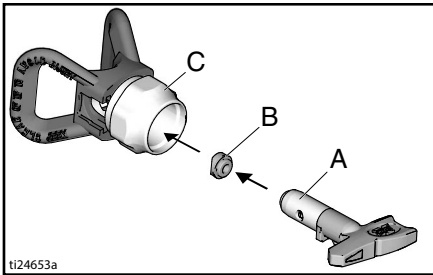

3. Insert Spray Tip.

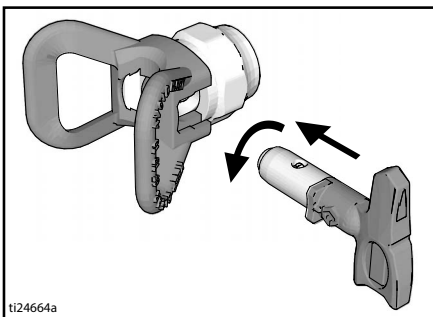

4. Screw assembly onto gun. Tighten.

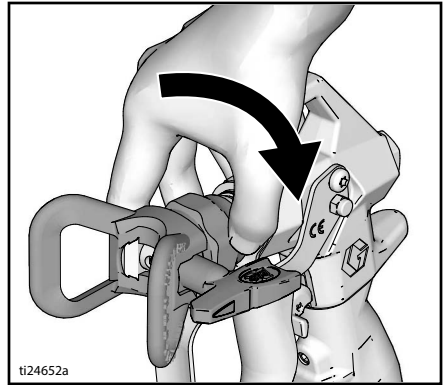

### Spray

**NOTE:** If spraying oil-based or flammable material, follow **Grounding Instructions**, page 10.

When a RAC X™ FF LP Fine Finish Low Pressure reversible spray tip is used, spraying pressure can be lowered. Spraying at a lower pressure results in less overspray and reduces spray tip wear. Adjust the sprayer pressure to minimize overspray.

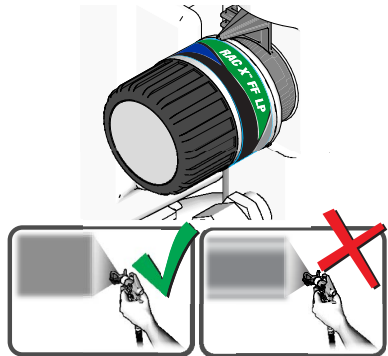

Atomized, evenly distributed fan pattern

Tails

1. Spray test pattern. Adjust pressure to eliminate heavy edges.

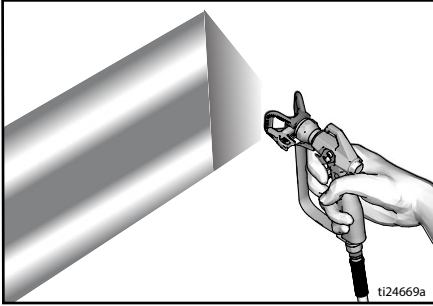

2. Use smaller tip size if pressure adjustment cannot eliminate heavy edges.

3. Hold gun perpendicular, 10-12 in. (25-30 cm) from surface. Spray back and forth; overlap by 50%.

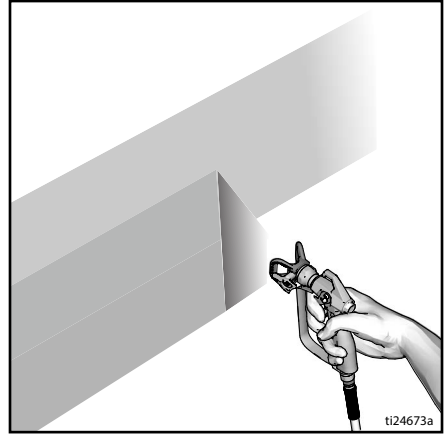

4. Trigger gun after moving. Release trigger before stopping. For additional spraying information, see separate gun manual.

# Operation

## Clear Tip Clog

				
<p>To avoid injury, never point gun at your hand or into a rag!</p>				

1. Release trigger. Engage trigger lock. Rotate Spray Tip. Disengage trigger lock. Trigger gun at waste area to clear clog.

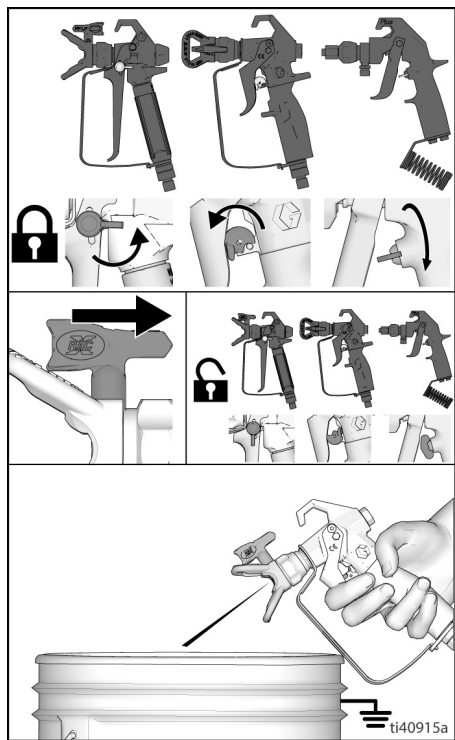

2. Engage trigger lock. Return Spray Tip to original position. Disengage trigger lock and continue spraying.

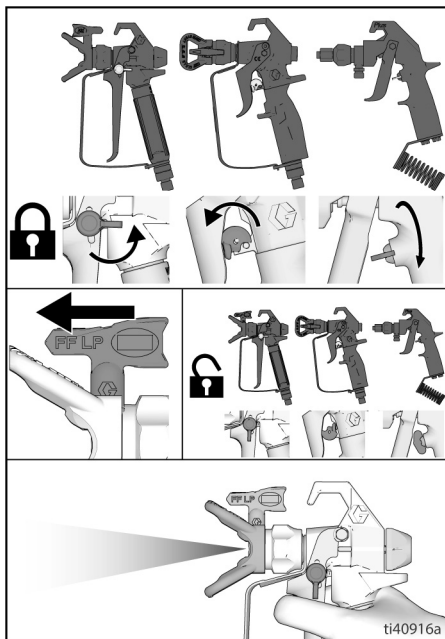

## Cleanup

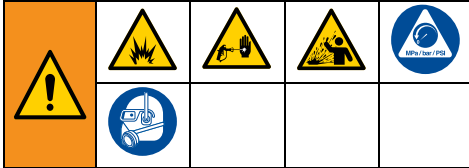

To avoid serious injury from fire and explosion when using oil-based or flammable materials:

- Do not spray solvents through the spray tip. Always remove tip guard and spray tip before flushing. Clean tip guard and spray tip in a bucket of compatible solvent.
- Clean in a well-ventilated area. Keep a good supply of fresh air moving through the area.
- When flushing with solvents, always ground the sprayer and waste container.

1. When using oil-based or flammable material, follow **Grounding Instructions**, page 10.
2. Perform **Pressure Relief Procedure**, page 12.
3. Remove tip guard and spray tip. For additional information, see separate gun manual.

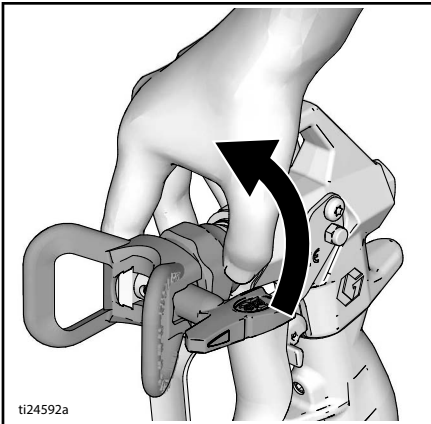

4. Remove fluid intake and drain tube from paint, wipe excess paint off outside.

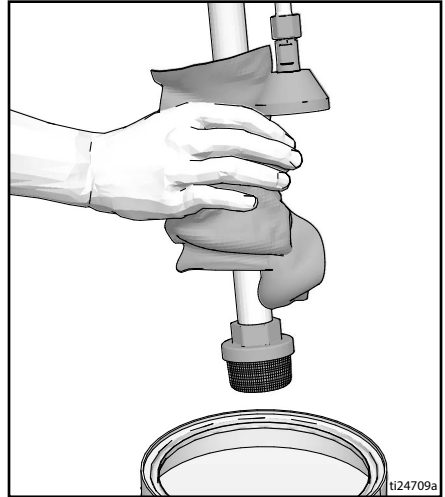

5. Place fluid intake in flushing fluid, see **Cleaning Fluid Compatibility**, page 26. Place drain tube in waste pail.

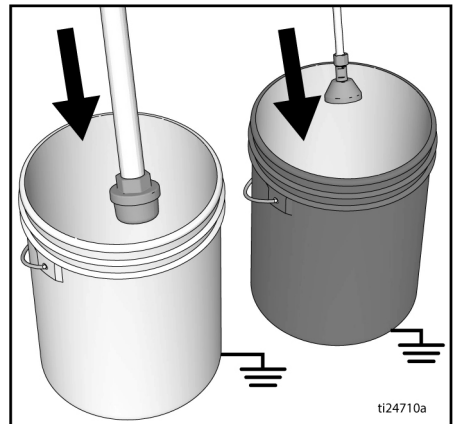

6. Turn prime/spray valve horizontal, to spray position.

# Operation

7. Increase pressure 1/2 turn to start motor. Hold gun against grounded paint or waste pail. Disengage trigger lock. Trigger gun and increase pressure until the pump runs steady and flushing fluid appears.

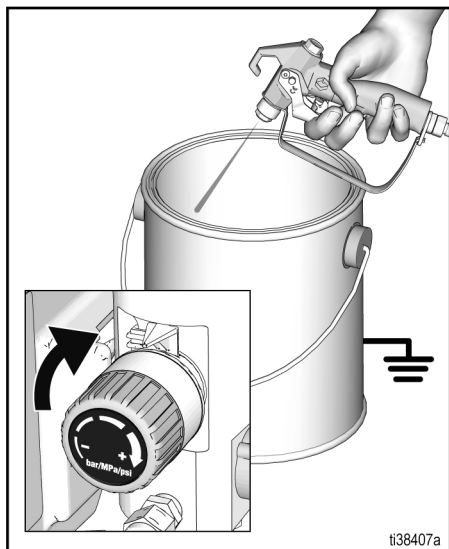

9. While continuing to trigger gun, turn prime/spray valve down. Then, release gun trigger. Allow flushing fluid to circulate until fluid comes out of drain tube clear.

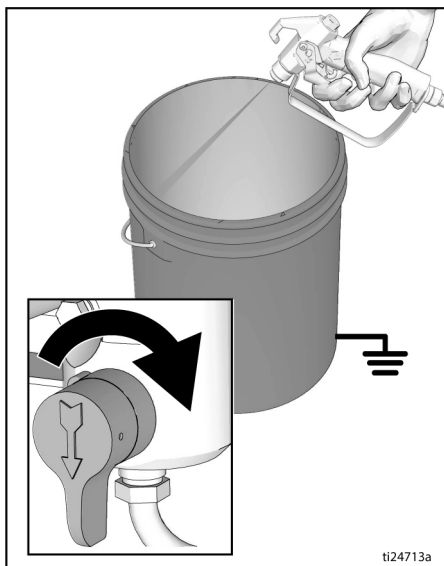

8. Stop triggering gun. Move gun to grounded waste pail, hold gun against pail, trigger gun to thoroughly flush system.

10. Raise fluid intake above flushing fluid.

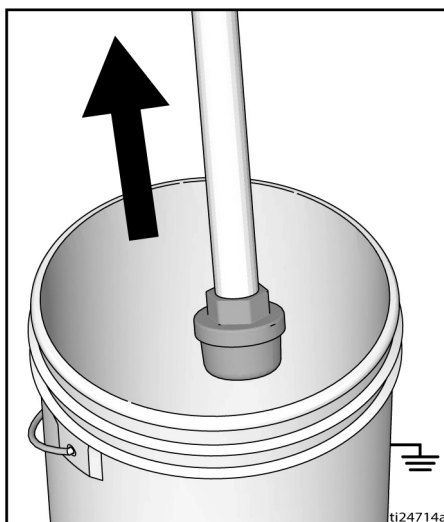



11. Turn prime/spray valve horizontal. Trigger gun into grounded flushing or waste pail for 20 seconds to purge fluid from hose.
12. Engage trigger lock.

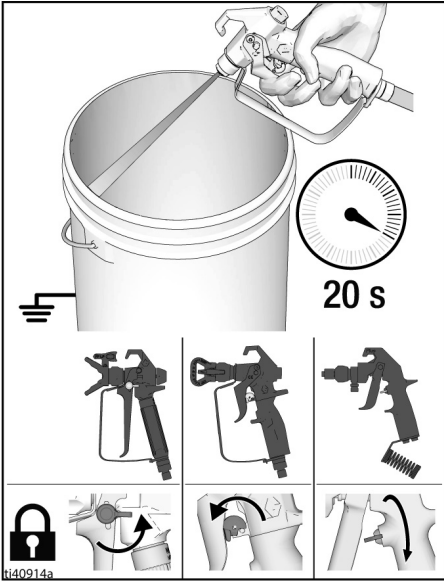

13. Turn pressure control knob to the lowest pressure setting and turn ON/OFF switch to **OFF** position. Power button is illuminated when power is **ON**. Remove battery.

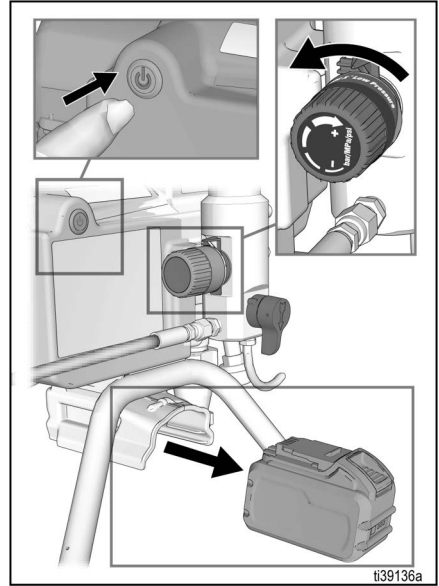

14. Perform **Pressure Relief Procedure**, page 12.
15. Remove filters from gun and sprayer if installed. Clean and inspect. Install filters. See separate gun manual.

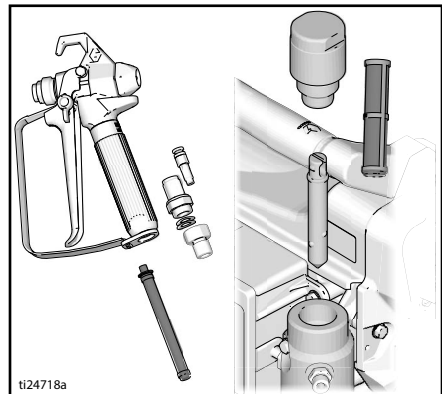

# Operation

16. If flushing with water, flush again with mineral spirits or Pump Armor™ to leave a protective coating to prevent freezing or corrosion.

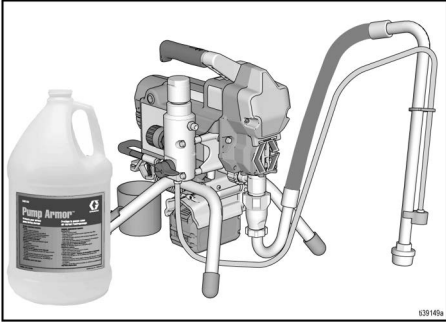

17. Wipe sprayer, hose and gun with a rag soaked in water or mineral spirits.

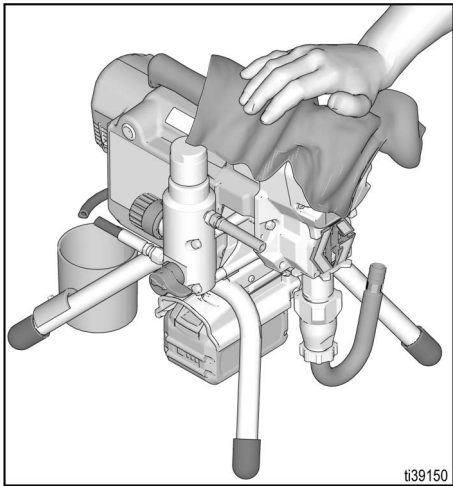

## Cleaning Fluid Compatibility

- When spraying **water-based** materials, flush the system thoroughly with water.
- When spraying **oil-based or flammable** materials, flush the system thoroughly with mineral spirits or compatible flushing solvent. When flushing with solvents, always follow **Grounding Instructions**, page 10.
- To spray **water-based** materials **after spraying oil-based or flammable** materials, flush the system thoroughly with water first. The water flowing out of drain tube should be clear and solvent-free **before** you begin spraying the water-based material.
- To spray **oil-based or flammable** materials **after spraying water-based** materials, flush the system thoroughly with mineral spirits or a compatible flushing solvent first. The solvent flowing out of the drain tube should not contain any water. When flushing with solvents always follow **Grounding Instructions**, page 10.
- To avoid fluid splashing back on your skin or into your eyes, always aim gun at inside wall of pail.

## Maintenance

Routine maintenance is important to ensure proper operation of your sprayer. Maintenance includes performing routine actions which keep your sprayer in operation and prevents trouble in the future.



Activity	Interval
Inspect/clean sprayer filter, fluid inlet strainer, and gun filter.	Daily or each time you spray
Inspect motor shield vents for blockage.	Daily or each time you spray
Fill TSL by adding through TSL fill point.	Daily or each time you spray
<p>Check sprayer stall.</p> <p>With sprayer gun NOT triggered, sprayer motor should stall and not restart until gun is triggered again.</p> <p>If sprayer starts again with gun NOT triggered, inspect pump for internal/external leaks and check prime/spray valve for leaks.</p>	Every 1000 gallons (3785 liters)
<p>Throat packing adjustment</p> <p>When pump packing begins to leak after extended use, tighten packing nut down until leakage stops or lessens. This allows approximately 100 gallons of additional operation before a repacking is required. Packing nut can be tightened without O-ring removal.</p>	As necessary based on usage

## Troubleshooting

### Mechanical/Fluid Flow



1. Follow **Pressure Relief Procedure**, page 12, before checking or repairing.
2. Check all possible problems and causes before disassembling the unit.

Problem	What to Check If check is OK, go to next check	What to Do When check is not OK, refer to this column
Pump output is low	Spray tip worn.	Follow <b>Pressure Relief Procedure</b> , page 12, then replace tip. See separate gun or tip manual.
	Spray tip clogged.	Relieve pressure. Check and clean spray tip.
	Paint supply.	Refill and reprime pump.
	Intake strainer clogged.	Remove and clean, then reinstall.
	Intake valve ball and piston ball are not seating properly.	Remove intake valve and clean. Check balls and seats for nicks; replace if necessary. See pump manual. Strain paint before using to remove particles that could clog pump.
	Fluid filter or tip filter is clogged or dirty.	Clean filter.
	Prime/spray valve leaking.	Follow <b>Pressure Relief Procedure</b> , page 12, then repair prime/spray valve.
	Verify pump does not continue to stroke when gun trigger is released. (prime/spray valve not leaking.)	Service pump. See pump manual.
	Leaking around throat packing nut which may indicate worn or damaged packings.	Replace packings. See pump manual. Also check piston valve seat for hardened paint or nicks and replace if necessary. Tighten packing nut/wet-cup.
	Battery has insufficient charge.	Charge battery.

Problem	What to Check If check is OK, go to next check	What to Do When check is not OK, refer to this column
Pump output is low	Pump rod damage.	Repair pump. See pump manual.
	Low stall pressure.	Turn pressure knob fully clockwise. Make sure pressure control knob is properly installed to allow full clockwise position. If problem persists, replace pressure control.
	Piston packings are worn or damaged.	Replace packings. See pump manual.
	O-ring in pump is worn or damaged.	Replace o-ring. See pump manual.
	Intake valve ball is packed with material.	Clean intake valve. See pump manual.
	Large pressure drop in hose with heavy materials.	Reduce overall length of hose.
Motor runs but pump does not stroke	Connecting rod assembly damaged. See pump manual.	Replace connecting rod assembly. See pump manual.
	Gears or drive housing damaged.	Inspect drive housing assembly and gears for damage and replace if necessary.
Excessive paint leakage into throat packing nut	Throat packing nut is loose.	Remove throat packing nut spacer. Tighten throat packing nut just enough to stop leakage.
	Throat packings are worn or damaged.	Replace packings. See pump manual.
	Displacement rod is worn or damaged.	Replace rod. See pump manual.
Fluid is spitting from gun	Air in pump or hose.	Check and tighten all fluid connections. Cycle pump as slowly as possible during priming.
	Spray tip is partially clogged.	Clear tip. See <b>Clear Tip Clog</b> , page 22.
	Fluid supply is low or empty.	Refill fluid supply. Prime pump. See pump manual. Check fluid supply often to prevent running pump dry.

# Troubleshooting

Problem	What to Check If check is OK, go to next check	What to Do When check is not OK, refer to this column
Pump is difficult to prime	Air in pump or hose.	Check and tighten all fluid connections. Cycle pump as slowly as possible during priming.
	Intake valve is leaking.	Clean intake valve. Be sure ball seat is not nicked or worn and that ball seats well. Reassemble valve.
	Pump packings are worn.	Replace pump packings. See pump manual.
	Paint is too thick.	Thin the paint according to supplier recommendations.
Sprayer operates for 5 to 10 minutes then stops	Pump packing nut too tight. When pump packing nut is too tight the packings on the pump rod restrict pump action and overloads the motor.	Loosen pump packing nut. Check for leaks around throat. If necessary, replace pump packings. See Pump manual.
	Battery has insufficient charge.	Charge battery.
Sprayer makes no sound when pressure control is ON and ON/OFF switch is ON (illuminated)	ON/OFF switch light blinks two times when pressure control is ON. Indicates incorrect voltage.	Replace battery with a charged battery.  Battery has reached end of life. Replace the battery.
	ON/OFF switch light blinks three times when pressure control is ON. Indicates battery temperature is too hot or too cold.	Allow battery to cool down or warm up to room temperature.
	ON/OFF switch light blinks four times when pressure control is ON. Indicates locked rotor condition.	Replace pump and/or motor assembly.
	ON/OFF switch light blinks five times when pressure control is ON. Indicates motor temperature is too hot.	Allow motor to cool down to room temperature.
ON/OFF switch does not illuminate when pressed.	Indicates battery is not installed, has insufficient charge, or is damaged.	Install battery correctly, ensure battery is fully charged, or replace battery.
	Control board is damaged.	Replace control board.
	Power switch is damaged.	Replace power switch.
ON/OFF switch is constantly illuminated (does not turn off).	Control board is damaged.	Replace control board.

## Electrical

Symptom: Sprayer does not run, stops running, or will not shut off.



1. Perform **Pressure Relief Procedure**, page 12.
2. Install fully charged battery, see **Battery Installation and Removal**, page 17.
3. Turn the ON/OFF switch **OFF**, wait 30 seconds and then turn power back **ON** again (this ensures sprayer is in normal run mode).
4. Turn pressure control knob clockwise 1/2 turn.

Problem	What to Check	How to check
Sprayer does not run at all.	Check battery charge.	Press charge level indicator on battery. Charge battery or install a new battery, if needed.
	Check pressure control connections.	Make certain connector is clean and firmly connected.
	Check pressure control.	Connect known good pressure control. If the motor runs, replace pressure control.
	Check motor leads.	Make certain terminals are clean and firmly connected.
Sprayer will not shut off after reaching or exceeding maximum pressure.	Check pressure control.	Disconnect pressure control, if sprayer still runs, replace control board. If the sprayer stops, replace pressure control.
Basic electrical problems	Motor leads are securely fastened and properly mated	Replace loose terminals; crimp to leads. Be sure terminal are firmly connected. Clean circuit board terminals. Securely reconnect leads.

# Parts

## Parts

### 390 and ES 500 Stencil Stand Sprayer Parts

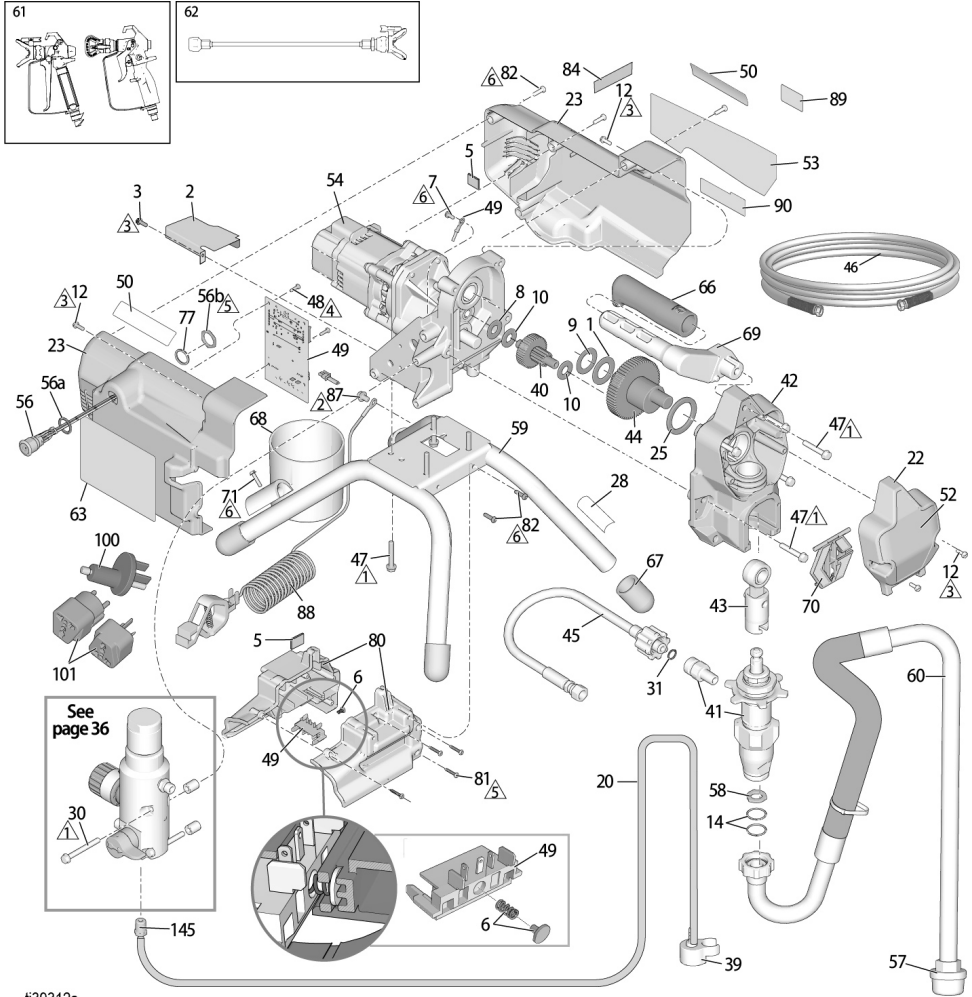

ti39312a

Ref.	Torque	Ref.	Torque	Ref.	Torque	Ref.	Torque
△1	140-160 in-lbs. (15.8-18.1 N•m)	△3	23-27 in-lbs (2.6-3.1 N•m)	△5	10-20 in-lbs (1.13-2.26 N•m)	△7	40-50 in-lbs (4.5-5.6 N•m)
△2	80-90 in-lbs (9-10.2 N•m)	△4	8-10 in-lbs (0.9-1.13 N•m)	△6	25-35 in-lbs (2.8-4 N•m)		



## 390 and ES 500 Stencil Stand Sprayers Parts List

Ref.	Part	Description	Qty.	Ref.	Part	Description	Qty.
1	107434	BEARING, thrust	1	58	115099	WASHER	1
2	25U231	BRACKET, cover	1	59	20A271	FRAME, stand mount	1
3	117501	SCREW, mach, hex hd.	1	60	246386	HOSE, suction set, <i>includes 14, 37, 91</i>	1
5	20A450	GASKET	2	61	See page 38	GUN, spray	1
6	20A052	SPRING BUTTON, assembly	1	62	20A925	KIT, extension, gun, tip, (Models: 25U513, 25U514)	1
7	115498	SCREW, mch, slot/hex, wash hd	1	63 ▲	See page 38	LABEL, warning	1
8	116073	WASHER, thrust	1	66	116139	GRIP, handle	1
9	116074	WASHER, thrust	1	67	15G857	CAP, leg	4
10	116079	BEARING, thrust	2	68	287903	CUP, suction/drain	1
12	117501	SCREW, mach, slot hex wash hd	4	69	287072	HANDLE <i>includes 47, 66</i>	1
14	117559	O-RING	2	70	17C483	COVER, pump rod	1
20	249051	KIT, tube, drain <i>includes 39, 145</i>	1	71	127914	SCREW, drill, hex washer head	1
22	17C539	COVER, front	1	77	100422	WASHER, lock	1
23 *		SHIELD, motor, <i>includes 87, 12, 48, 84, 89, 90</i>	1	80	19D606	BATTERY COMPARTMENT	1
	25U300	Models: 25T804, 25T863, 25T943, 25T882, 25U513, 25U514	1	81	17R614	FASTENERS, battery compartment	4
	826283	Models: 826280		82	115477	FASTENER	6
25	180131	BEARING, thrust	1	84	17P924	LABEL, A+	1
28		LABEL, identification	1	88	237686	WIRE, ground	1
30	17C735	SCREW, hex hd.	2	87	112798	FASTENER	1
31	16H137	PACKING, O-RING	1	89	16D576	LABEL, USA	1
34 ▲	See page 38	CARD, medical alert (not shown)	1	90	20A335	LABEL, brand, DEWALT	1
39	244035	DEFLECTOR, barbed	1	99	20A162	BATTERY (not shown) 60V, 6ah, USA/CA (Models 25T804, 826280, 25U513)	1
40	249194	GEAR, reducer	1		20A163	54V, 6ah, EMEA/UK (Models 25T863, 25T943, 25U14)	1
41		PUMP, displacement	1		20A164	54V, 6ah, ANZ (Model 25T882)	1
	17C487	North America			20A756	60V, 9ah, USA/CA (Models 25T804 826280, 25U13)	1
	17C488	Asia/ANZ/Japan			20A757	54V, 9ah, EMEA/UK (Models 25T863, 25T943, 25U14)	1
	17C489	Europe			20A758	54V, 9ah, ANZ (Model 25T882)	1
42	24W817	HOUSING, drive <i>includes 47</i>	1	100	25U295	ADAPTER, ground, outlet	1
43	24W640	ROD, connecting	1	101	16H592	ADAPTER, plug, grounded CEE 7/7 (Models: 25T863, 25T943, 25U514)	1
44	24X020	GEAR, crankshaft <i>includes 25</i>	1		16H835	AS3112/ANZ (Model: 25T882)	
45	24W830	KIT, hose, cpld <i>includes 31</i> (Models 25T804, 826280, 25T863, 25T943, 25T882)	1		16H593	BS-1363/UK (Model: 25T943)	
	20A939	KIT, hose, cpld, <i>includes 31</i> (Models 25U513, 25U514).	1	110	20A165	CHARGER, fast, DEWALT (not shown) 60V, USA/CA (Models 25T804, 826280, 25U513)	1
46	See page 38	HOSE, cpld, 1/4 in. x 25 or 50 ft	1		20A166	54V, EMEA/UK (Models 25T863, 25T943, 25U514)	
47	117493	SCREW, mach, hex washer hd	9		20A167	54V, ANZ (Model 25T882)	
48	119236	SCREW, torx	2	145	M70809	FITTING, barbed, hose	1
49	20A555	KIT, control board, 390 cordless, <i>includes 7, 48</i>	1		206994	FLUID, TSL, 8 oz (not shown)	1
50	See page 38	LABEL, top	2		124507	ADAPTER, UK power, model 25T943 (not shown)	1
52	See page 38	LABEL, front	1				
53	See page 38	LABEL, side	1				
54	20A554	KIT, motor, module, <i>includes 1, 8, 9, 10, 25</i>	1				
56	19D605	SWITCH, power	1				
56a		O-RING	1				
56b		NUT	1				
57	246385	STRAINER, 7/8-14 unf	1				

▲ Replacement safety labels, tags, and cards are available at no cost.

\* Order branding label #53 and warning label #63 separately.

## 390 Hi-Boy Sprayers Parts

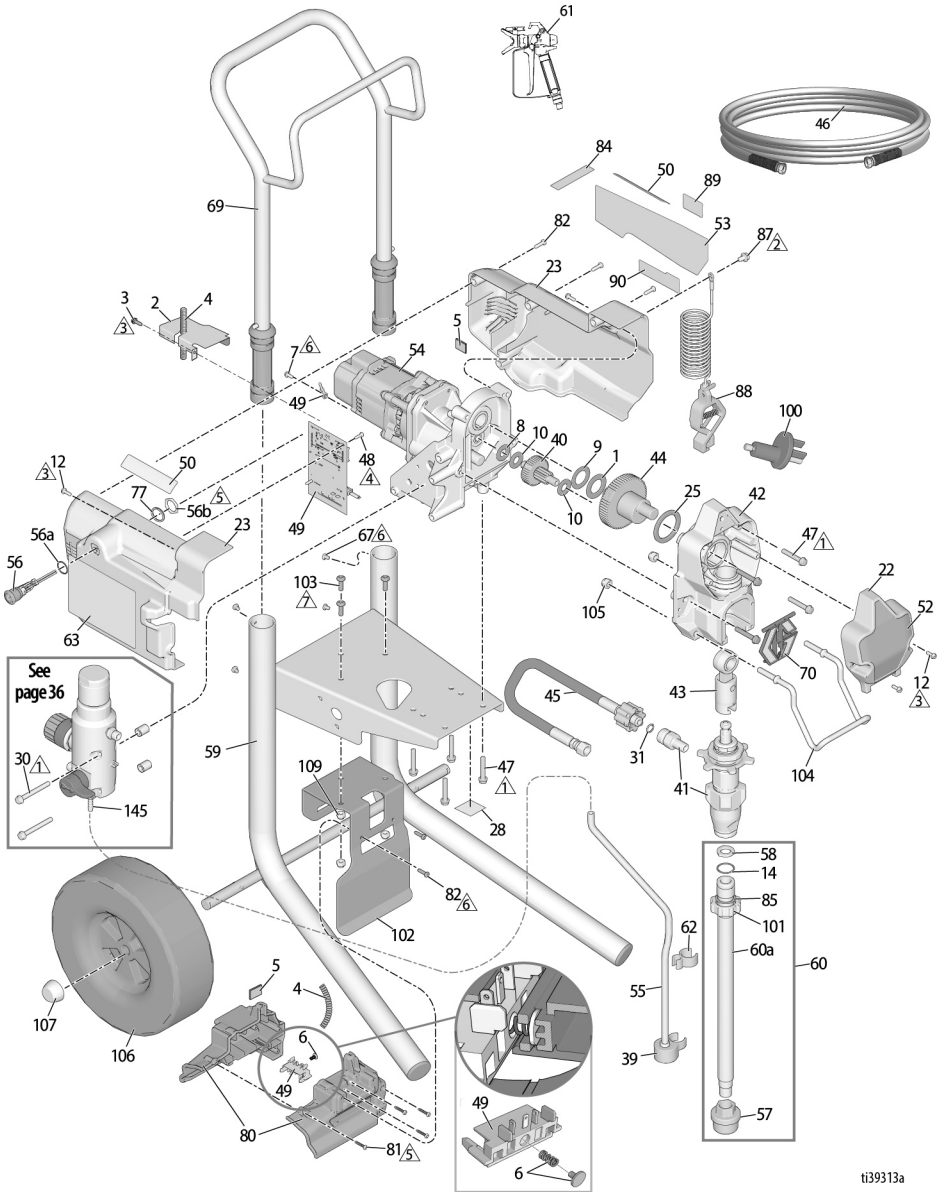

ti39313a

Ref.	Torque	Ref.	Torque	Ref.	Torque	Ref.	Torque
1	140-160 in-lbs. (15.8-18.1 N·m)	3	23-27 in-lbs (2.6-3.1 N·m)	5	10-20 in-lbs (1.13-2.26 N·m)	7	40-50 in-lbs (4.5-5.6 N·m)
2	80-90 in-lbs (9-10.2 N·m)	4	8-10 in-lbs (0.9-1.13 N·m)	6	25-35 in-lbs (2.8-4 N·m)		

## 390 Hi-Boy Sprayer Parts List

Ref.	Part	Description	Qty.	Ref.	Part	Description	Qty.
1	107434	BEARING, thrust	1	55	15K092	TUBE, drain	1
2	25T886	BRACKET, cover	1	56	19D605	SWITCH, power	1
3	117501	SCREW, mach, hex hd.	1	56a		O-RING	1
4	16V903	CONDUIT, corrugated	1	56b		NUT	1
5	20A450	GASKET	2	57	235004	STRAINER, 3/4-16 unf	1
6	20A052	SPRING BUTTON, assembly	1	58	115099	WASHER	1
7	115498	SCREW, mch, slot/hex, wash hd	1	59	17C485	FRAME, stand mount	1
8	116073	WASHER, thrust	1	60	25C786	KIT, suction intake <i>includes 14, 58, 85, 101, 60a, 57</i>	1
9	116074	WASHER, thrust	1	60a	17C949	TUBE, suction, intake	1
10	116079	BEARING, thrust	2	61	See page 38	GUN, spray	1
12	117501	SCREW, mach, slot hex wash hd	4	62	195400	CLIP, spring	1
14	103413	O-RING	1	63 ▲	See page 38	LABEL, warning	1
22	17C539	COVER, front	1	67	109032	SCREW	4
23	25U300	KIT, shield, motor, <i>includes 87, 12, 48, 52, 53, 84, 89, 90</i>	1	69	287489	HANDLE, assembly, Hi-Cart	1
25	180131	BEARING, thrust	1	70	17C483	COVER, pump rod	1
28		LABEL, identification	1	77	100422	WASHER, lock	1
30	17C735	SCREW, mach hex	2	80	19D606	BATTERY COMPARTMENT	1
31	16H137	O-RING	1	81	17R614	FASTENERS, battery compartment	4
34 ▲	See page 38	CARD, medical alert (not shown)	1	82	115477	SCREW, torx	6
39	244035	DEFLECTOR, barbed	1	84	17P924	LABEL, A+	1
40	249194	GEAR, reducer	1	85	15B652	WASHER	1
41		PUMP, displacement	1	87	112798	FASTENER	1
	17C487	North America		88	237686	WIRE, ground	1
	17C488	Asia/ANZ/Japan		89	16D576	LABEL, USA, w/ global	1
	17C489	Europe		90	20A335	LABEL, brand, DEWALT	1
42	24W817	HOUSING, drive <i>includes 47</i>	1	99	20A162	BATTERY 60V, USA/CA (not shown)	2
43	24W640	ROD, connecting	1	100	25U295	ADAPTER, ground, outlet	1
44	24X020	GEAR, crankshaft <i>includes 25</i>	1	101	15E813	NUT	1
45	24W830	KIT, hose, cpld <i>includes 31</i>	1	102	20A386	BRACKET, battery	1
46	See page 38	HOSE, cpld, 1/4 in. x 25 or 50 ft	1	103	128795	SCREW, torx	3
47	117493	SCREW, mach, hex washer hd	9	104	17C990	HANGER, pail	1
48	119236	SCREW, torx	2	105	111040	NUT, lock	2
49	20A555	KIT, board, control, 390 cordless, <i>includes 7, 48</i>	1	106	119451	WHEEL	2
50	20A330	LABEL, top	2	107	119452	CAP, hub	2
52	See page 38	LABEL, front	1	109	102040	NUT, lock	3
53	See page 38	LABEL, side	1	110	20A165	CHARGER, fast, DEWALT, 60V, USA/CA (not shown)	1
54	20A554	KIT, motor, module, 390 cordless, <i>includes 1, 8, 9, 10, 25</i>	1	145	M70809	FITTING, barbed, hose	1
					206994	FLUID, TSL, 8 oz (not shown)	1

▲ Replacement safety labels, tags, and cards are available at no cost.

## Control Box and Filter

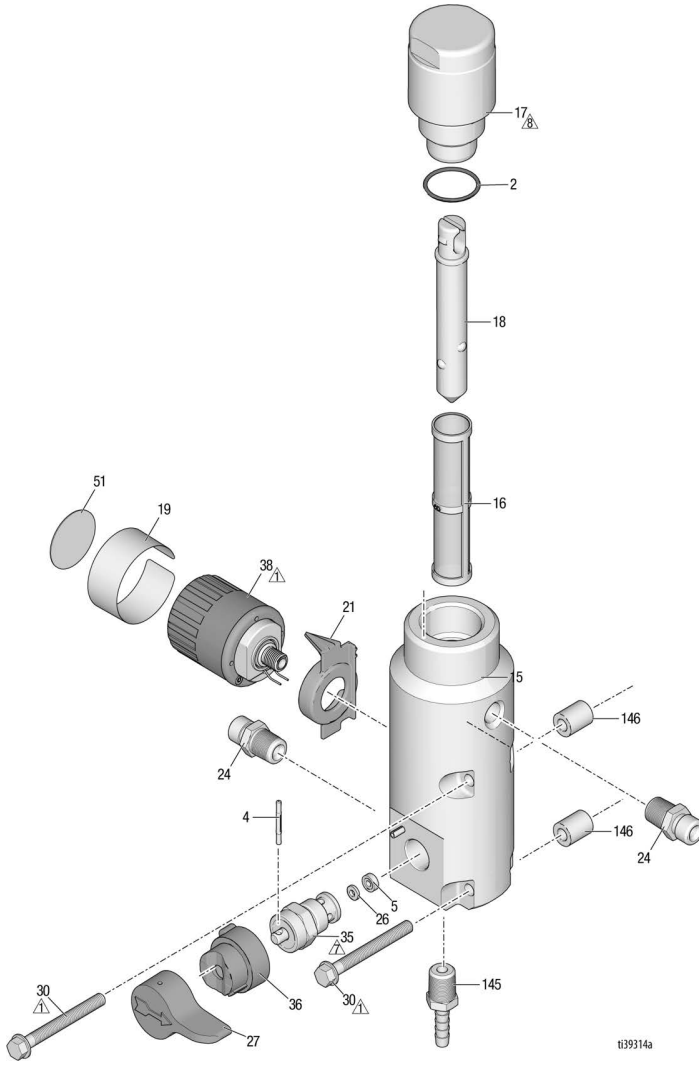

Ref.	Torque	Ref.	Torque	Ref.	Torque	Ref.	Torque
	140-160 in-lbs. (15.8-18.1 N•m)		130-140 in-lbs (14.7-16.9 N•m)		48-72 in-lbs (5.4-8.1 N•m)		

## Control and Filter Parts List

Ref.	Part	Description	Qty.	Ref.	Part	Description	Qty.
2	117828	PACKING, o-ring	1	24	162453	NIPPLE, (1/4 npsm x 1/4 npt) (Models 25T804, 826280, 25T863, 25T943, 25T882)	2
4	111600	PIN, grooved	1		196181	NIPPLE, (1/4 npsm x 1/4 npt) (Models 25U513, 25U514)	2
5	277364	GASKET, seat, valve	1	26	15E022	SEAT, valve	1
15		MANIFOLD, fluid	1	27	187625	HANDLE, valve, drain	1
	17C590	Sprayer (Models: 25T804, 25T805, 826280, 25U513)		30	17C735	SCREW, mach, HWH	2
	17C591	Sprayer (Models: 25T863, 25T882, 25T943, 25U514)	1	35	239914	VALVE, drain, <i>includes 5, 26</i>	1
16		FILTER, fluid (tall manifold)	1	36	224807	BASE, valve	1
	246425	30 mesh (gray)		38	20A556	KIT, control, pressure, cordless, <i>includes 19, 20, 51</i>	1
	246384	60 mesh, original (black)		51	20A474	LABEL, control	1
	246382	100 mesh (blue)		145	M70809	FITTING, barbed	1
	246383	200 mesh (red)		146	17D294	SPACER, manifold	2
17		CAP, manifold	1		115523	GAUGE, pressure, fluid (on select models). <i>Not shown</i>	1
	287902	KIT, cap, tall manifold, <i>includes 18</i>		119783		FITTING, tee, swivel (on models with gauge)	1
18	15B071	INSERT, filter, tall	1				
19	20A475	LABEL, PC	1				
21	17C725	INDICATOR, control pressure	1				

# Gun, Hose and Labels

## Gun, Hose and Labels

Sprayer Model (Series)	Ref. 46 Hose, 1/4 in. x 50 ft	Ref. 61 Gun, Spray	Ref. 50, Label, Top	Ref. 52 Label, Front	Ref. 53 Label, Side	Ref. 34 Card, Medical Alert ▲	Ref. 63 Label, Danger ▲
25T804 & 25T805 &	240794	20A479	20A330	20A328	20A329	222385 #	20A030 #
25T863 \$ 25T943 \$	240794	288438	20A428	20A333	20A334	222385 \$	20A480 \$
25T882 @	240794	17Y043	20A330	20A328	20A329	17A134 %	20A481 %
826280 &	826079	826282	20A330	20A331	20A332	222385 #	20A030 #
25U513 &	249080	248157 / 20A925	20A330	19D342	19D343	222385 #	20A030 #
25U514 \$	249080	248157 / 20A925	20A330	19D342	19D343	222385 #	20A480 \$
# – English, Spanish, French			@ – ANZ				
% – English, Chinese, Korean			\$ – Europe				
& – North America			* – AP				
▲ Replacement safety labels, tags, and cards are available at no cost.							

# Wiring Diagram

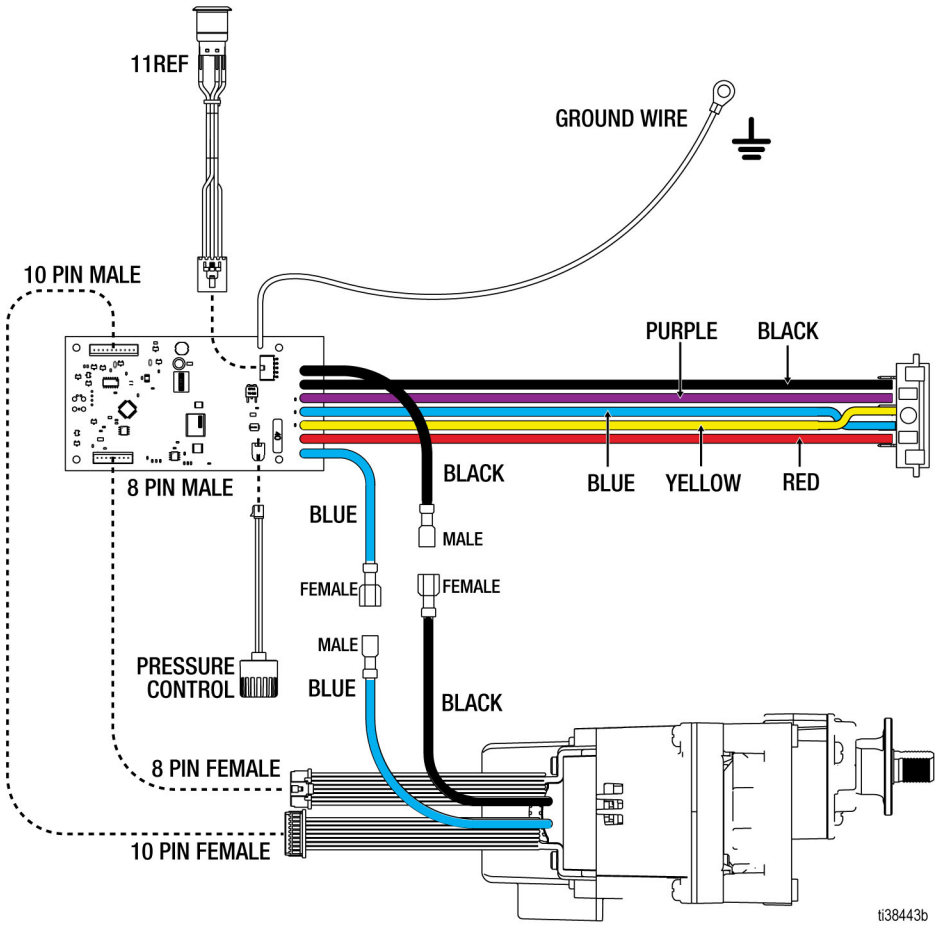

t38443b

# Technical Specifications

## Technical Specifications

390 PC / ES 500 Stencil Cordless		
	US	Metric
Sprayer		
Maximum fluid working pressure		
390 PC / ES 500 Stencil Cordless	3300 psi	228 bar, 22.8 MPa
Maximum Delivery		
390 PC / ES 500 Stencil Cordless	0.47 gpm	1.8 lpm
Maximum Tip Size		
390 PC / ES 500 Stencil Cordless	0.021	0.021
Fluid Outlet		
	1/4 in. npsm	1/4 in. npsm
Dimensions		
Height		
Stand	18.5 in.	47 cm
Hi-Boy	28.25 in. (Handle down) 38.25 in. (Handle up)	71.8 cm (Handle down) 97.2 cm (Handle up)
Length		
Stand	16 in.	40.6 cm
Hi-Boy	23.25 in.	59.1 cm
Width		
Stand	14 in.	35.6 cm
Hi-Boy	20.5 in.	52.1 cm
Weight		
Stand (with battery)	31 lb. (33 lb.)	14 kg (15 kg)
Hi-Boy (with battery)	58 lb. (60 lb.)	26 kg (27 kg)
Noise** (dBa) @ 70 psi (0.48 MPa, 4.8 bar)		
Sound pressure	90 dBa	
Sound power	100 dBa	
Materials of Construction		
Wetted materials on all models	zinc- and nickel-plated carbon steel, nylon, stainless steel, PTFE, acetal, leather, UHMWPE, aluminum, tungsten carbide, polyethylene, fluoroelastomer, urethane	
Notes		
* Startup pressures and displacement per cycle may vary based on suction condition, discharge head, air pressure, and fluid type.		
** Sound pressure measured 3 feet (1 meter) from equipment. Sound power measured per ISO-3744.		
<b>All trademarks or registered trademarks are the property of their respective owners.</b>		



# California Proposition 65

## CALIFORNIA RESIDENTS

 **WARNING:** Cancer and reproductive harm –  
[www.P65warnings.ca.gov](http://www.P65warnings.ca.gov).

# Graco Standard Warranty

## Graco Standard Warranty

Graco warrants all equipment referenced in this document which is manufactured by Graco and bearing its name to be free from defects in material and workmanship on the date of sale to the original purchaser for use. With the exception of any special, extended, or limited warranty published by Graco, Graco will, for a period of twelve months from the date of sale, repair or replace any part of the equipment determined by Graco to be defective. This warranty applies only when the equipment is installed, operated and maintained in accordance with Graco's written recommendations.

This warranty does not cover, and Graco shall not be liable for general wear and tear, or any malfunction, damage or wear caused by faulty installation, misapplication, abrasion, corrosion, inadequate or improper maintenance, negligence, accident, tampering, or substitution of non-Graco component parts. Nor shall Graco be liable for malfunction, damage or wear caused by the incompatibility of Graco equipment with structures, accessories, equipment or materials not supplied by Graco, or the improper design, manufacture, installation, operation or maintenance of structures, accessories, equipment or materials not supplied by Graco.

This warranty is conditioned upon the prepaid return of the equipment claimed to be defective to an authorized Graco distributor for verification of the claimed defect. If the claimed defect is verified, Graco will repair or replace free of charge any defective parts. The equipment will be returned to the original purchaser transportation prepaid. If inspection of the equipment does not disclose any defect in material or workmanship, repairs will be made at a reasonable charge, which charges may include the costs of parts, labor, and transportation.

**THIS WARRANTY IS EXCLUSIVE, AND IS IN LIEU OF ANY OTHER WARRANTIES, EXPRESS OR IMPLIED, INCLUDING BUT NOT LIMITED TO WARRANTY OF MERCHANTABILITY OR WARRANTY OF FITNESS FOR A PARTICULAR PURPOSE.**

Graco's sole obligation and buyer's sole remedy for any breach of warranty shall be as set forth above. The buyer agrees that no other remedy (including, but not limited to, incidental or consequential damages for lost profits, lost sales, injury to person or property, or any other incidental or consequential loss) shall be available. Any action for breach of warranty must be brought within two (2) years of the date of sale.

**GRACO MAKES NO WARRANTY, AND DISCLAIMS ALL IMPLIED WARRANTIES OF MERCHANTABILITY AND FITNESS FOR A PARTICULAR PURPOSE, IN CONNECTION WITH ACCESSORIES, EQUIPMENT, MATERIALS OR COMPONENTS SOLD BUT NOT MANUFACTURED BY GRACO.** These items sold, but not manufactured by Graco (such as electric motors, switches, hose, etc.), are subject to the warranty, if any, of their manufacturer. Graco will provide purchaser with reasonable assistance in making any claim for breach of these warranties.

In no event will Graco be liable for indirect, incidental, special or consequential damages resulting from Graco supplying equipment hereunder, or the furnishing, performance, or use of any products or other goods sold hereto, whether due to a breach of contract, breach of warranty, the negligence of Graco, or otherwise.

### **FOR GRACO CANADA CUSTOMERS**

The Parties acknowledge that they have required that the present document, as well as all documents, notices and legal proceedings entered into, given or instituted pursuant hereto or relating directly or indirectly hereto, be drawn up in English. Les parties reconnaissent avoir convenu que la rédaction du présente document sera en Anglais, ainsi que tous documents, avis et procédures judiciaires exécutés, donnés ou intentés, à la suite de ou en rapport, directement ou indirectement, avec les procédures concernées.

## Graco Information

For the latest information about Graco products, visit [www.graco.com](http://www.graco.com).

For patent information, see [www.graco.com/patents](http://www.graco.com/patents).

**TO PLACE AN ORDER**, contact your Graco distributor or call 1-800-690-2894 to identify the nearest distributor.

*All written and visual data contained in this document reflects the latest product information available at the time of publication.*

*Graco reserves the right to make changes at any time without notice.*

Original instructions. This manual contains English. MM 3A8179

**Graco Headquarters:** Minneapolis

**International Offices:** Belgium, China, Japan, Korea

**GRACO INC. AND SUBSIDIARIES • P.O. BOX 1441 • MINNEAPOLIS MN 55440-1441 • USA**

**Copyright 2021, Graco Inc. All Graco manufacturing locations are registered to ISO 9001.**

[www.graco.com](http://www.graco.com)

Revision C, December 2021